

**THE RIGHT TO INFORMATION ACT, 2005
(Refer to Chapter II Section 4(1)(b))**

ANDHRA PRADESH STATE WAREHOUSING
CORPORATION
Hyderabad : Head office

**Office of the Managing Director,
A.P.State Warehousing Corporation ,
“Warehousing Sadan”, 2nd Floor,
Behind Gandhi Bhavan, Nampally,
Hyderabad – 500 001**

**ANDHRA PRADESH STATE WAREHOUSING CORPORATION
HYDERABAD.**

**Chapter 1
Introduction**

The Andhra Pradesh State Warehousing Corporation was established by the State Government on 5-8-1958. The Agriculture Produce (Development and Warehousing) Corporations Act, 1956 was repealed and replaced by the Warehousing Corporations Act, 1962 (58 of 1962).

The Corporation was set up by the State Government after notification in the Official Gazette with the previous approval of the Central Warehousing Corporation under the Warehousing Corporations Act, 1962 which is a Statutory Corporation established by the Government of Andhra Pradesh under an Act of Parliament. The Central Warehousing Corporation, a Government of India undertaking and the Government of Andhra Pradesh are the shareholders holding 50% shares each.

According to Section 20 of the Warehousing Corporations Act, the general superintendence and management of the affairs of SWC shall vest with board of directors. The Board of Directors consists of 5 Directors nominated by CWC and 5 Directors nominated by the State Government and the Managing Director appointed by the State Government. The Chairman of the Board shall be appointed by the State Government from nominated directors with previous approval of Central Warehousing Corporation.

According to Section 25 of the above Act, there shall be an Executive Committee consisting of Chairman, Managing Director, two directors nominated by State Government and one by Central Warehousing Corporation.

The main objective was to develop warehousing by providing scientific storage facilities so as to minimize wastage and losses in storage, assistance in orderly marketing , price support/price control measures taken up by the Government.

According to Section 24 of the Warehousing Corporations Act, 1962, the following are the functions of the State Warehousing Corporation.

- 1) To acquire land and build godowns at suitable places within the State for Providing storage facilities.
- 2) To arrange facilities for transportation of the produce to the Warehouses and from Warehouses to other places.
- 3) To act as an agent of the Central Warehousing Corporation or State Government for the purpose of purchase, sale, storage and distribution of agricultural produce, seeds, manures, fertilizers and other notified commodities.

The Corporation is playing an important role in the State by providing substantial storage space for storage of rice and other commodities meant for the Public Distribution System. Besides farmers and traders, storage facilities are being availed of by Fertilizers' manufacturers, Cooperative Apex Bodies, Government undertakings, Government Departments, etc.

To encourage the farmers to avail the Warehousing facilities offered by the Corporation, a rebate of 35% on storage charges is being allowed and also 10% of the storage space available in the godowns is specifically earmarked for their use by way of Warehouse Receipts.

Chapter 2
Organisation, Functions and Duties
[Section 4(1)(b)(i)]

2.1 Particulars of the organization, functions and duties:-

Sl. No.	Name of the Organization	Address	Functions	Duties
1	C/o. Managing Director, A.P.State Warehousing Corporation.	“Warehousing Sadan”, Behind Gandhi Bhavan, Nampally, Hyderabad	1) To acquire land and build godowns at suitable places within the State for providing storage facilities. 2) To act as nodal storage agent of State Govt.	To arrange facilities for transportation of the produce to the Warehouses and from Warehouses to other places.

Chapter 3
Powers and Duties of Officers and Employees
[Section 4(1)(b)(ii)]

Sl. No.	Name of the officer/employee	Designation	Duties allotted	Powers
1	Sri Md.Shafiquzzaman, I.A.S., Mg Director.	Managing Director.		
		Administrative:	<p>He shall have the powers to carry on the authorized business of the Corporation in accordance with the instructions which the Board of Directors or the Executive Committee may issue from time to time and he shall decide whether any suit or proceedings be instituted or defended by or against the corporation subject to such directions as the Board of Director may give from time to time.</p> <p>He shall act as Controlling and Distributing Officer in respect of all funds of the Corporation and shall operate account either singly or jointly with a Director or any Officer of the Corporation authorized in this behalf by the Board of Directors from time to time and to draw, accept and endorse bills of exchange and other instruments in the current and authorized business of the corporation and to sign all other accounts, receipts and documents connected with such business,.</p> <p>The MD shall organize and supervise the office of the Corporation, maintain discipline and exercise such powers in connection with appointments, promotions, termination of service and other disciplinary matters and</p>	

			leave of the staff of the Corporation as may be vested by the Board of Directors, in this behalf and to allocate duties to the staff and make such other arrangements as may be necessary for the efficient discharge of the functions of the corporation.	
		Financial:		
		Other:		
2	Sri S.Suryanarayana,	Secretary Addl/Charge.	<p>Payment of Annual subscription of A.P.Chambers of Commerce/Govt. Gazette.</p> <p>Payment of fees and expenses (upto Rs.3000/-) to Govt., Pleader/Legal Advisor for attending Court cases relating to land acquisition cases.</p> <p>Payment of charges to Director of Printing & Stationery for publishing notification in Govt Gazette relating to amendments under APSWC Regulations, 1965/APSWC Employees Regulations,1965.</p> <p>Incurring expenditure upto Rs.5000/- for arranging lunch/dinner in connection with the visit of officials from CWC/SWC etc., or on the eve of conferences of Regional Managers/Fertilizer officials including purchase of momentos.</p> <p>Payment of charges for printing the Annual Report with the approval of the MD.</p> <p>Payment of Advance amount of Rs.10,000/- to be kept as deposit with the revenue authorities for making</p>	

			<p>payment to news papers for publishing the DN & DDS proposals (As per GO).</p> <p>Signing of proposals for acquisition/alienation of land with prior approval of the MD.</p> <p>Attending meetings, Legislative work, work relating to Association of SWCs and matters of urgent importance.</p> <p>Sign the Vakalat Forms and Counter Affidavits on behalf of the Corporation.</p>	
		Administrative:		
		Financial:		
		Other		
3	Sri K.Vijay Bhasker	Executive Engineer.		
		Administrative:	<p>Sanction/Drawal/Authorisation/Ratification of Advance/Expenditure upto Rs.10,000/- on each item of purchase/works, for the purchase of Ammonia Papers, Roofing, Compound, 'J' Bolts, to attend to small repairs and maintenance to godowns, construction works, stacking or restacking of cement and sheets, etc., municipal sanctions, miscellaneous expenditure pertaining to Engineering Section, authorizing payment excess over tender amounts at final bill state, entrustment of works on nomination at estimate rates, in consultation with the General Manager(F&A)</p> <p>Payment of Municipal Taxes for Corporation owned</p>	

			godowns etc., and property taxes. Monitoring repair, maintenance and fuel utilization of vehicles at Headquarter and Regional offices. Payment of bills shall be made after approval of the MD.	
		Financial:		
		Other		
4	E.Prasad Rao	General Manager (P & A):	Sanction of :-	
		Administrative:	Earned Leave and Medical leave with prior approval in case of all employees other than Secretary, Executive Engineer, Construction Engineers, General Managers, Regional Managers and Ware-House Managers Gr.I and equivalent cadres. In cases of post-fact approvals of above mentioned leaves, approvals of the Managing Director have to be obtained for all cadres of employees. Encashment of leave in respect of all employees other than Secretary, EE, CEs, GMs, RMs and Warehouse Managers Gr.I and equivalent cadres.. Sanction of LTC in respect of all employees other than Secretary, EE, CE, GMs, RMs and Warehouse Managers Gr.I. Permission to move personal	

			<p>effects to all employees except Secy, EE, Ces, GMs and RMs.</p> <p>Sanction of Annual Increments, PF., Increments and Pay Fixation, in respect of all employees other than Secy, EE, Ces, GMs, RMs and Ware-House Managers Gr.I and equivalent cadres in consultation with GM(F&A).</p> <p>Sanction of Advance for purchase of: Bicycles within the limits of budgetary provisions.</p> <p>Training Programmes (upto Gr-III Warehouse Managers level).</p> <p>Payment of Leave Salary and Pension contribution in respect of all officers on deputation jointly with GM(F&A).</p> <p>All matters pertaining to installations, shifts, etc., of telephones at Head Office and field units including Regional offices.</p> <p>Monitoring of tour programmes of the RMs, sanctioning of petrol allowance to eligible employees upto Grade-II Warehouse Managers and equivalent cadres.</p> <p>Sanction and payment of Leave Salary and Pension contribution and reimbursement of Medical Expenses to the employees working on deputation basis.</p>	
5.	S.Suryanarayana	General		

		Manager (F&A) Administrative	<p>Monitoring of receipts, payments, income-expenditure progress of all Warehouses and briefing the MD every Monday.</p> <p>Approval of Tour Programme of staff working under him, whenever they are deputed for realization or bills.</p> <p>Imprest Bills of Head Office.</p> <p>Sanction of PF loans to all employees upto Grade-III Warehouse Managers and equivalent cadres within the frame work of rules. For any special relaxation the file should be submitted to Managing Director.</p> <p>Drawal of interest on PF investment from Banks/Post Offices/RBI and operation of PF account with prior approval of the MD.</p> <p>To issue cheques upto a payment of bills amounting to Rs.5,00,000/- under joint signature along with Secretary or GM(M&QC) or GM(B&L) after the approval of the MD or the concerned GM as per delegation orders of the MD. Cheques for payment of more than Rs.5.00 lakhs shall be put up for signature of the MD.</p> <p>To pass Pay bills – Head Office and warehouses.</p> <p>To pass Bonus bills after the sanction is given for such payments by the MD.</p> <p>To monitor imprest bills of</p>	
--	--	---------------------------------	--	--

			warehouses passed by the RMs and brief the MD every fortnight.	
6.	Sri Md.Shareef Ali	General Manager (B & L)		
		Administrative	<p>Reservation of godown space to all bulk depositors and correspondence.</p> <p>Sanction of License Fee as per the rules.</p> <p>To sanction godowns rent up to Rs.1.00 per Sft per month while the proposals upto Rs.0.75 ps/sft will be approved by the RMs concerned.</p> <p>To sanction of shifting charges upto Rs.5000/- at a time on receipt of proposals from RMs concerned.</p> <p>To release all EMDs/SDs collected from H & T Contractors after eazpirty of their contract period.</p> <p>To release EMDs of all unsuccessful H & T Contractors who are fifth lowest and above Immediately after the tenders are approved and to release EMDs of other unsuccessful tenderers after the contract is awarded and agreement is received from the appointed contractor.</p> <p>To sanction advance not exceeding Rs.5000/- at a time towards departmental H & T work where there is no permanent/adhoc H&T Contractor in consultation with GM(F & A).</p>	

			<p>To release the tender publication bills received from Telugu Samacharam etc., and to publish H&T notification as per the rules.</p> <p>All the Bills regarding H 7 T and Godown Rents upto Rs.5.00 lakhs shall be sanctioned by GM(B&L). Bills in excess of Rs.5.00 lakhs shall put up to the MD for approval.</p>	
7.	Sri S.Praveen Kumar.	General Manager M&QC)		
		Administrative.	<p>To sanction an amount upto Rs.3000/- at a time for expenditure towards repairs to equipments, payment of freight for arranging local dispatches or receipts.</p> <p>Forwarding gain/loss statement pertaining to foodgrain storage falling below the range of 1.5% in a period of one year.</p> <p>To place order with the suppliers (approved by CPC) for purchase of Insecticides/Fumigants at the CPC approved rates with the approval of the MD each time.</p> <p>Sanctioning of advance upto Rs.25,000/- to the Warehouse Managers for meeting the expenditure on salvaging, operation in the event of damages to stocks due to fire, floods, cyclones, etc., in consultation with the General Manager(F&A) and disposal of damaged stocks after inviting tenders/quotations and refund of EMDs to the</p>	

			<p>tenderers.</p> <p>Disposal of obsolete articles like dunnage, polythene covers and other unserviceable articles shall be arranged through towards and approved for acceptance by the Managing Director.</p> <p>Convener of Purchase Committee.</p> <p>All the Bills regarding P&M charges upto 3.00 lakhs shall be sanctioned by GM(M&QC) . Bills in excess of Rs.3.00 lakhs shall be put up to the M.D., for approval.</p> <p>Purchase of Stationery upto the value of Rs.2000/-(local) each time within the limits of Budget.</p> <p>Printing of forms, registers, publicity material etc, with the approval of the MD.</p> <p>Maintenance and repairs of office equipment including servicing of office equipment such as Air Conditioners, Air Coolers, Xerox Machines, Intercom installations, etc., subject to a maximum limit at a time upto Rs.5000/- within the budget allocation jointly with General Manager (F&A). For higher sanctions, approval of Managing Director is necessary.</p>	
8.	Regional Managers	Administrative.	<p>Scrutiny, passing and payment of all TA bills of Warehouse Managers and all other staff working at Warehouses in their respective Regions. However, the Regional Managers' TA bills will come</p>	

			<p>to the Head Office for passing and payment.</p> <p>Scrutiny, passing and payment of Imprest Bills of all Warehouses in their respective Regions.</p> <p>Scrutiny, passing and payment of Telephone bills, Electricity charges and Water Bills of Warehouses. Standards are laid down separately..</p> <p>Payment towards Warehouse License Fee.</p> <p>Payment towards shifting and restacking charges upto Rs.20,000/- - Shifting and restacking cost not exceeding Rs.2000/- per month in unusual/emergency cases.</p> <p>Write off sanction for unserviceable articles upto a value of Rs.10,000/- per annum and not exceeding Rs.1500/ds- per warehouse and their disposal by following prescribed procedure.</p> <p>Disposal of old newspapers, unserviceable empty gunnies and other scrap materials duly following the prescribed procedure.</p> <p>Sanction and payment towards Obsequies charges.</p> <p>Sanction and payment towards stitching charges towards Liveries.</p> <p>Account should be rendered before the 10th of succeeding month for the expenditure</p>	
--	--	--	--	--

			<p>incurred. Necessary formats are enclosed herewith in which accounts will be rendered by the Regional Manager under their signature.</p> <p>To begin with an amount of Rs.2.00 lakhs will be sent to Regional Manager and they are hereby informed to open an Account with SBI or SBH as the case may be.</p> <p>They are authorized to sign cheques upto a value of Rs.20,000/- on single signature.</p> <p>Copy of monthly bank Account should be sent to Head Office by 10th of succeeding month.</p> <p>Complete expenditure including fuel, major repairs and other administrative expenses per each Regional Office is limited to Rs.50,000/- per month. Expenditure exceeding this must be cleared by the Head Office.</p> <p>Accounts Books to be maintained at Regional Officer with the help of the Accounts clerk.</p> <p>Replenishment of Imprest Account is possible only after the account for the expenditure incurred is rendered.</p>	
--	--	--	---	--

Chapter 4
Procedure Followed in Decision-making Process
 [Section 4(1)(b)(iii)]

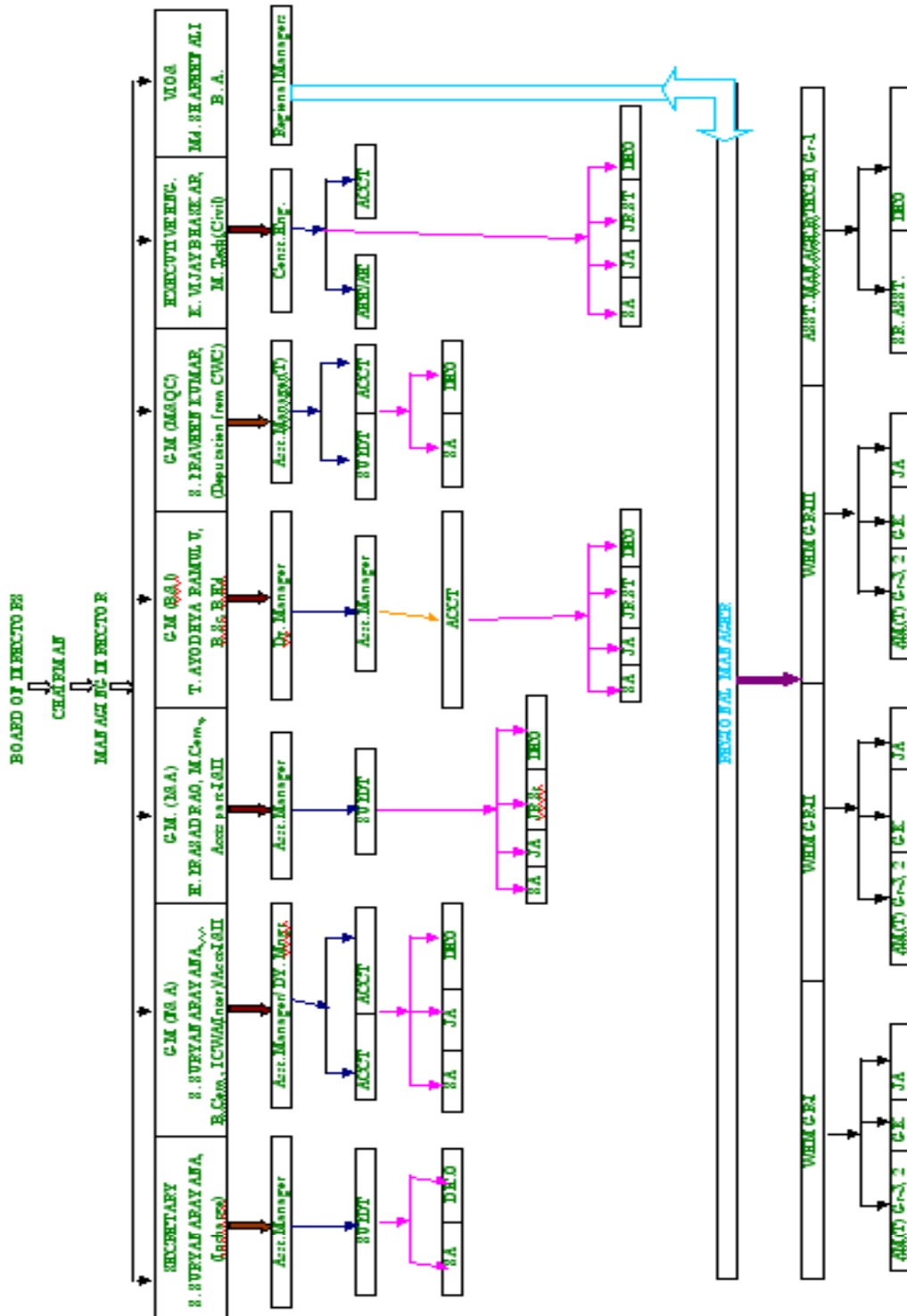

Chapter 5
Norms set for the Discharge of Functions
[Section 4(1)(b)(iv)]

Sl. No.	Function/service	Norms/standards of performance set	Time frame	Reference document prescribing the norms (Citizen's Charter, Service Charter etc)
1	Preservation & Maintenance	Settlement of bills	10 days*	Preservation & Maintenance Agreements
2	Handling & Transport bills	Settlement	10 days**	
3	Godown Rents	Settlement	Subject to realization of storage charges from FCI	
4	Civil Works Raising of bills as per Mile stones fixed.	Settlement	10 days	

* Subject to realization of storage charges

** Subject to release of Handling & Transport charges by the depositors

Chapter 6
Rules, Regulations, Instructions, Manual and Records, for Discharging Functions
[Section 4(1)(b)(v) & (vi)]

Sl. No	Description	Gist of contents	Price of the publication if priced
Rules & Regulations			
1	A.P.State Warehousing Corporation Regulations , 1965.	Govt. orders G.O.Ms.No.2660, Food and Agriculture, dated 4 th November, 1965, relating to Board Meetings, Service matters, etc.	---
2	Andhra Pradesh State warehousing Corporation Rules, 1965.	G.O.2659, Food & Agriculture (Agri.IV) Dept., dated 4 th November, 1965, in exercise of the powers conferred by Section 41 of the Warehousing Corporations Act,1962 (Central Act 58 of 1962).	---
Instructions			
1	---	---	
2			
...			
Manuals			
1	Functionary Manual (The Madras Ware-house Act 1951 and Madras Warehouse Rules 1953, and The Hyderabad Warehouse Regula-tion (The Hyderabad Act IX of 1955) and The Hyderabad Area Warehouse Rules 1959.	Duties and Responsibilities of Each functionary.	---
2			
...			
Records			
1	Business Review Reports.	Reports on Occupancy position of godowns	---
2			
...			
Publications			
1	---Nil---	---Nil---	---Nil---
2			
...			

Note:- Since no salable publications are available, it is proposed that the Information required will be provided @ Rs.1/- per page.

Chapter 7
Categories of Documents held by the Public Authority under its Control
[Section 4(1) (b) v (i)]

Sl. No.	Category of document	Title of the document	Designation and address of the custodian (held by / under the control of whom)
1.	Handling & Transport Contract Agreement	Tender afor Handling and Transport Operation	General Manager (B&L), Corporate office.
2.	Preservation and Maintenance Agree- ment.	Agreement on Preser- vation and Maintenance of stocks in godowns.	General Manager (M & QC) Corporate Office.
3.	Rental Agreement	Agreement entered into with Private Investors with regard to payment of godown rents.	Secretary Corporate office.
4.	Tripartite Agreement	Agreement entered between Banks-Investors- Corporation.	General Manager (F&A).
5.	Agreement with Private Investors.	Agreement entered with Investors prior to hiring godowns constructed by them.	Secretary Corporate Office.
6.	Agreement with FCI	Agreement with Food Corporation of India on guarantee of utilization of Investor godowns and payment of storage charges.	---do---
7.	Contract Service Agreements.	Agreement entered with individuals whose services were engaged in Corporation on contract basis.	General Manager (P&A) Corporate Office.

Chapter 8
Arrangement for Consultation with, or Representation by, the Members of the Public in
relation to the Formulation of Policy or Implementation thereof
[Section 4(1)(b)viii]

S. No.	Function/service	Arrangements for consultation with or representation of public in relations with policy formulation	Arrangements for consultation with or representation of public in relations with policy implementation
Note:- Policy issues are placed in the Board of Directors Meetings and implemented with prior consent of the Government.			

Chapter 9
Boards, Councils, Committees and other Bodies constituted as part of Public Authority
[Section 4(1)(b)v(iii)]

Name of Board, Council, Committee, etc.	Composition	Powers & Functions	Whether its Meetings open to Public/ Minutes of its Meetings accessible for Public
A.P.,State Warehousing Corporation.	The total no., of Board of Directors is 10, excluding the Managing Director. Five Directors are nominated by the Central Warehousing Corporation and other five directors are nominated by the State Govt.	Powers and functions of the directors as stated in the Warehousing Corporations Act, 1962, and State Government instructions, if any, from time to time.	---No---

Chapter 10
Directory of Officers and Employees
[Section 4(1)(b)(ix)]

WH_NAME	EMP_NAME	DESIG_NAME	ADDRESS	PHONE
HEAD OFFICE	Sri Md.Shafiquzzaman, I.A.S.	Managing Director	AP State Warehousing Corpn., 2 nd Floor, Warehousing sadan, Beside Gandhi Bhavan, Nampally, Hyderabad-01	040- 24603194
	S SURYANARAYANA	Secretary I/C		040-24609688
	K VIJAYA BHASKAR	Executive Engineer		040-24737377
	E PRASADA RAO	General Manager P&A		040-24732276
	MD SHAREEF ALI	General Manager B&L		
	S SURYANARAYANA	General Manager F&A		
	S.PRAVEEN KUMAR	General Manager M&QC		
	T AYODHYA RAMULU	VIO		
	S B SOMASEKHAR	W.H Manager Grade I		
	N PANDURANGA REDDY	W.H Manager Grade I		
	CH LIMEN	W H Manager Grade II		
	G NAGESWARA RAO	W H Manager Grade II		
	M CHANDRAVATHI	W H Manager Grade III		
	D M KUMAR	W H Manager Grade III		
	G INNA REDDY	Superintendent		
	P ROHINI	Accountant		
	S VARALAXMI	Accountant		
	K SUDHA RANI	Accountant		
	T VISAKHA	Accountant		
	K V RAMANA MURTHY	Accountant		
	B SUGUNA KUMARI	Senior Steno Cum PA to MD		
	M V RAJYALAXMI	Senior Steno Cum PA to MD		
	G.SAMBASIVA RAO	Senior Asst		
	M VENKATESWARLU	Senior Asst		
	K S VICTORIA	Senior Asst		
	CH MALATHI	Senior Asst		
	N JAYALAXMI	Senior Asst		
	MOHD MUJEEBUR RAHMAN	Senior Asst		
	M VIKRAM	Senior Asst		
	D NIRMAL SINGH	Senior Asst		
M S G PATNAIK	Senior Asst			

WH_NAME	EMP_NAME	DESIG_NAME	ADDRESS	PHONE
	D CHANDRA SEKAR	Senior Asst		
	D MADHAVA RAO	Senior Asst		
	N.VENKATESWARLU	Senior Asst		
	K.PADMAVATHI	Senior Asst		
	P.VENUGOPAL	Senior Asst		
	M A RAHEEM	Asst.Warehouse Manager		
	M.SUJATHA	Junior Assistant		
	G.RAVINDRANATH	Typist		
	D.TULASIRAM	Driver		
	MD ISMAIL	Driver		
	K VENKATESHWAR RAO	Driver		
	D PENTAIAH	Attender		
	V YADAAIAH	Attender		
	MOHD SARDAR	Attender		
	K ANJANEYULU	Attender		
	P BALAIAH	Peon		
	K PANDU RANGA REDDY	Peon		
	S.RAVINDER RAO	G C P		
	N.NARASIMHA	G C P		
	Md.OBAIDUR RAHMAN	G C P		
	L NAGENDAR	G C P		
	C.SURESH KUMAR	Deputy Manager(I.T)		
	T SAI BABA	Wire Men		
	R B KOTESWARAMMA	Construction Engineer		
KADAPA(RO*)	N V S N MURTHY	Regional Manager	AP State Warehousing Corpn.,	085622244647
	RMD. MUSTAF JAVEED	Typist	KADAPA, D.C. Road, KADAPA DIST. 516 001.	
	T NATARAJA RAMANA	Driver		
KAKINADA (RO)**	CH SUBBA RAO	Regional Manager	AP State Warehousing Corpn.,	08842376415
	Y SURYA KUMARI	W.H Manager Grade I	D.No.67-3-3/1, MSN Junior College Lane, Ashok Nagar, Kakinada, E.G.DISTRICT 533 003. Tel No :	
	B JEEVAN KUMAR	Construction Engineer		
	DABBA DEVADASU	Driver		
	A PALLA RAJU	G C P		
	CH VENKATA RAMANA RAO	G C P		
KARIMNAGAR (RO)**	N GANGADHARA RAO	Regional Manager	AP State Warehousing Corpn.,	08782243143
			D.No.2-10-1086, N.R.Complex, First Floor,	

WH_NAME	EMP_NAME	DESIG_NAME	ADDRESS	PHONE
			Opp: Shiva Theatre, Jyothinagar, KARIMNAGAR DIST. 505 001.	
NALGONDA (RO) **	G RAGHAVULU	Regional Manager	AP State Warehousing Corpn., 6-6-61, Hyderabad Road, Ravindranagar Colony, Nalgonda NALGONDA DIST 508 001	08682225177
TADEPALLI GUDEM(RO*)	G PRABHAKAR REDDY	Regional Manager	A.P.State Warehousing Corpn., D.No. 2-15-12 (5) Bandarivari Street Tadepalligudem, W.G.DIST. 534 101	08818244739
	MD ISRARUL HAQUE	Driver		
VIJAYAWADA (RO) **	M RAMULU	Regional Manager	Regional Manager AP State Warehousing Corpn., D.No.26-22-30, First Floor, Nootan Towers, Opp.Jayaram Theater, Mudunurivari Street, Gandhinagar, VIJAYAWADA 520003.	08662575707
	K S N REDDY	Asst.Warehouse Manager		
	P ASEERVADAM	G C P		
VIZIANAGARAM (RO*)	K A RASHEED	Regional Manager	AP State Warehousing Corpn., D.No.5-11-33, Gavara Street, Opp: MRO Office, Vizianagaram, VIZIANAGARAM DIST. 535 001.	08922221214
	G.Lakshminarayana	Typist		
	S.DURGA RAO	Driver		
HYDERABAD (RO)**	B LALITHABAYAMMA	W.H Manager Grade I	Regional Manager AP State Warehousing Corpn., Opp. Central Jail, Musheerabad, HYDERABAD	04027592019
	ASHA DEVI	W.H Manager Grade I		
	NAGA RAJA RAO K	W.H Manager Grade I		
	K.RAVI	Driver		
	M NAGENDER	Fitter		
ADILABAD (IG)	D SURYANARAYANA	W H Manager Grade III	AP State Warehousing Corpn., M/S. Astalaxmi Spinning Light Mills, Industrial Area, ADILABAD – 504001.	08732 233134
	G CHANDRA SEKAR	G C P		
AKIVIDU-1 (IG)	B JAYARAMI REDDY	W H Manager Grade III	AP State Warehousing Corpn., AKIVIDU I C/o. Rama Raju	08816 253599
“	CH RAMA RAO	Junior Assistant	Warehousing Complex, Siddapuram, Chinna Millipadu Post, AKIVIDU. W.G.Dist.534 235.	
AKIVIDU-2 (IG)	N SATYANARAYANA	Asst Manager(Tech) GR.I	AP State Warehousing Corpn., AKIVIDU II C/o. Annapurna	08816 255050
“	K ATCHANNA	Asst.Warehouse Manager	Storages, Post : AL Bhimavaram, AKIVIDU, W.G. Dist 534235.	
“	P SATYANARAYANA	Junior Assistant		
ALLAGADDA	B BASAVAMMA	W.H Manager Grade I	AP State Warehousing Corpn.,	08519 220049

WH_NAME	EMP_NAME	DESIG_NAME	ADDRESS	PHONE
“	K.PUSHPALATHA	Senior Asst	ALLAGADDA Sri T.V.R.C.Oil Mill, Kandukur Road, ALLAGADDA, KURNOOL DIST. 518543. “	“
	N VENKATA REDDY	G C P		
	P VENKATESWARLU	G C P		
AMADALAVALASA	G P BHANJ DEO	W H Manager Grade II	AP State Warehousing Corpn., AMADALAVALASA Krishnapuram Road, AMADALAVALASA, SRIKAKULAM DIST 532 185.	08942 2886487
	V.VENKATAVARA PRASAD	Asst.Warehouse Manager		
	K.RAVI RAJ	Asst.Warehouse Manager		
	A MALLESWAR RAO	G C P		
	G LAXMI	G C P		
	D A SURYANARAYANA	G C P		
	V ADINARAYANA	G C P		
	S A RAMZAN	G C P		
	J.NAGAMANI	G C P		
ANANTHAPUR	L NARASIMHA SWAMY	W.H Manager Grade I	AP State Warehousing Corpn., ANANTAPUR 19/664, Gooty Road, ANANTAPUR - 515005.	08554 230024
	T.PRABHAKAR REDDY	Asst.Warehouse Manager		
	D SUBBA REDDY	Asst.Warehouse Manager		
	S OSMAN MIAH	G C P		
	K G S PRASAD	G C P		
ANAPARTHI(IG)	S S C PAPA REDDY	W H Manager Grade III	AP State Warehousing Corpn., ANAPARTHY(Pera Ramachandrapuram) E.G.DIST	08857 228917
BALABHADRAPURAM (IG)	K BHULOKARDHANA RAO	W H Manager Grade II	AP State Warehousing Corpn., BALABADRAPURAM, H.No. 5-520, Rajamagaram Road, BIKKAVOLU (m) E.G.DISTRICT 533 343	08857237383
	M S JAGANMOHANA RAO	Asst.Warehouse Manager		
BAPATLA	P MUNIKRISHNA REDDY	Asst.Warehouse Manager	AP State Warehousing Corpn., BAPATLA, Guntur Dist. 522 101.	08643 224117
	D VENKATESHWARA RAO	Junior Assistant		
	G SURYANARAYANA	Attender		
	CH SAMUEL	G C P		
	G.VENKATESWARAMM A	G C P		
BAPATLA(IG)	N ANNAPURNA	W H Manager Grade II	A.P.State Warehousing Corpn., BAPATLA Guntur District.	08643 272329
	M A RASHEED	Asst Manager(Tech)Gr-II		
	M SREENIVASA RAO	Asst.Warehouse Manager		

WH_NAME	EMP_NAME	DESIG_NAME	ADDRESS	PHONE
BHIMAVARAM	B RAMACHANDRA RAO	Asst.Warehouse Manager	AP State Warehousing Corpn., BHIMAVARAM, W.G.District 534 203.	08816 233451
	G GUNNESWARA RAO	Asst.Warehouse Manager	“	“
	BH SURYANARAYANA	G C P	“	“
BHONGIR	B S HANS RAJ	W.H Manager Grade I	AP State Warehousing Corpn., H.No. 1-3-33, Tagore Road, BHONGIR, Nalgonda District 508 116.	08685 242169
	J V L NARASIMHA RAO	Asst.Warehouse Manager		
	CH NARASIMHA	G C P		
BIBINAGAR(IG)	V KISHORE KUMAR	W.H Manager Grade I		
	M V SESHARATNAM	W H Manager Grade II		
	MD SHAKIR HUSSIN	Asst.Warehouse Manager		
BICCAVOLE (IG)	N SREERAMA RAJU	W H Manager Grade III	AP State Warehousing Corpn., BHKKAVOLU Nallamilli Road, E.G.District 533343.	8857237475 6
“	B RAMA SWAMY	Asst.Warehouse Manager		
BOBBILI(IG)	A SUNDARA NARAYANA	W H Manager Grade III	AP State Warehousing Corpn., BOBBILI KHASAPETA (POST) Antipeta Village Vizianagaram Dist 535546	08944 250178
CHENGICHERLA(IG)	J SHANKAR RAO	W.H Manager Grade I	AP State Warehousing Corpn., CHENGICHERLA Boduppall Post R.R. District – 500 039	.
	D NARASIMHA	Junior Assistant		
CHIPURUPALLI	M V S BHATLU	W H Manager Grade III	AP State Warehousing Corpn., CHEEPURUPALLI Kapusangam Village, Garidi Mandal, Vizianagaram District – 535 128.	08952 280111
CHIRALA	M VENKAT RAO	W H Manager Grade II	AP State Warehousing Corpn., CHIRALA Karamchedu Road, Perala	08594 232146
	S SESHAGIRI RAO	G C P		

WH_NAME	EMP_NAME	DESIG_NAME	ADDRESS	PHONE
	P.V.RAMANAIAH	G C P	(P) CHIRALA,	
	K.PRAMEELA	G C P	PRAKASAM DIST. 523 156.	
CHIRALA(IG)	K YOHAN	W.H Manager Grade I	A.P.State Warehousing Corpn., Desaipeta Post, Vetapalem Mandalam, Challareddypalem-523 187. CHIRALA Prakasam District.	9848121512
	M S S VARA PRASAD	Asst Manager(Tech)Gr- II		
	S ASHOK REDDY	Asst.Warehouse Manager		
	CH SREENIVASA RAO	Junior Assistant		
CHITTOOR	E Y DAS	W H Manager Grade II	AP State Warehousing Corpn., CHITTOOR High Road, CHITTOOR 517007.	08572 232004
	SREENIVASULU K	Attender		
CHITYAL(IG)	V K SURESH KUMAR	W.H Manager Grade I	AP State Warehousing Corpn., CHITYAL Warehousing Complex, Peddakaparti Village, Chityal Mandal, NALGONDA DIST. 508114.	08682 243695
	CH.UPENDRA RAO	W H Manager Grade III		
DHONE	C NAGABHUSHANAM	G C P	AP State Warehousing Corpn., DHONE, Kurnool Dist – 518 221	
DWARAPUDI	Y.RAJASREE	Senior Asst	AP State Warehousing Corpn., DWARAPUDI, Ramachandrapuram Road EAST GODAVARI 533 341.	
DWARAPUDI(IG)	D SIVA RAMA RAJU	Asst Manager(Tech)Gr-II	AP State Warehousing Corpn., CHOLANGI Vishwa Godowns, Yanam Road, CHOLLANGI, Kakinada. E.G.DIST. 533 461.	08857 226503
	CH UMA MAHESWARA RAO	Junior Assistant		
ELURU	K RAMA SUBBA REDDY	W H Manager Grade III	AP State Warehousing Corpn., ELURU W.G.District,534 007.	08812 231007
	V.PANDURANGA RAO	G C P		
	P.RAMACHANDRA SEKHAR RAO	G C P		
	V. SATYANARAYANA	G C P		
ELURU (IG)	B G SUNDER RAO	Asst.Warehouse Manager		08812 277677
	CHN DURGA PRASAD	Asst.Warehouse Manager		
GADWAL (IG)	T DAYA SHANKAR	Superintendent	AP State Warehousing Corpn., GADWAL Putanpalli, Gadwal Mandal, MAHABOBNAGAR Dist. 509 125.	08546 222331
GADWAL (IG)	M VENKATESWARLU	Junior Assistant	AP State Warehousing Corpn., GADWAL Putanpalli, Gadwal	08546 222331

WH_NAME	EMP_NAME	DESIG_NAME	ADDRESS	PHONE
			Mandal, MAHABOORNAGAR Dist. 509 125.	
GANAPAVARAM	B SUBBA RAO	W H Manager Grade III	AP State Warehousing Corpn., GANAPAVARAM, GUNTUR DIST. 522 619.	08647 254127
GANGURU (LABBIPET)	R.MANGAIAH	G C P	AP State Warehousing Corpn., D.No.11-479/SE Plant, AP Markfed, Autonagar, VIJAYAWADA – 520 007	0866 2546100
GUDIVADA	P. VENKATESWARLU	W.H Manager Grade I	AP State Warehousing Corpn., GUDIVADA Near Mandapadu, Railway Gate, Gudivada, KRISHNA DIST. 521 301.	08674 245404
	U VASANATAYYA	Asst.Warehouse Manager		
	V.Chinna	G C P		
	M BASAVA RAJU	G C P		
	V KRISHNA RAO	G C P		
GUDIVADA(IG)	B ESWAR RAO	Asst.Warehouse Manager	A.P.State Warehousing Corpn., Near Mandapadu,Railway Gate, GUDIVADA-521 301. Krishna District	9848515730
	DVN RAMACHANDRA RAO	Asst.Warehouse Manager		
	S.RAVI KUMAR	Asst Manager(Tech) Gr-III		
	P V RAGHAVALU	G C P		
GUDUR	P BALA RAJU	Asst.Warehouse Manager	AP State Warehousing Corpn., GUDUR H.No. 243, Opp. Government Hospital, Gudur, Nellore Dist. 524 101.	08624 251742
	R PENCHALAI AH	G C P		
GUNTUR	K SRINIVASA RAO	G C P	AP State Warehousing Corpn., GUNTUR C/O. SATYANARAYANA Godowns, H.No. 734, Old FCI godowns, Nallapadu Post, GUNTUR, GUNTUR DIST. 522 005.	08632 291283
	B.PURNACHANDRA REDDY	Asst.Warehouse Manager		
HINDUPUR	T NALLANNA	G C P	AP State Warehousing Corpn., HINDUPUR Near Agriculture Market Yard, HINDUPUR, Anantapur Dist. 515 202.	
HUZURABAD	P MALLIKARJUN	G C P	AP State Warehousing Corpn., HUZURABAD K.C.Camp, Huzurabad, Karimnagar District.505 498.	08727 252323
HUZURABAD (IG)	B PEDA SWAMY	W H Manager Grade II	A.P.State Warehousing Corpn., HUZURABAD Karimnagar District. “ “	08727 252522 “ “
	D V RAMANA RAO			
	P.PAPA RAO	Asst Manager(Tech) Gr-III		
HUZURNAGAR	V RAMULU	Superintendent	AP State Warehousing Corpn., HUZURNAGAR, Nalgonda District 508 202. “ “	08683 241116 “ “
	M.JAWAHAR BABU	Asst Manager(Tech) Gr-III		
	P VENKATESWARLU	G C P		

WH_NAME	EMP_NAME	DESIG_NAME	ADDRESS	PHONE
	R. VEERAI AH	G C P	“ “	
HUZURNAGAR (IG)	B SAMBASIVA RAO	W H Manager Grade III	A.P.State Warehousing Corpn., HUZURNAGAR Nalgonda District.	08683 246021 “ “
	S SURESH	Asst.Warehouse Manager	“	
	K SOMAIAH	G C P	“	
IDA BOLLARAM	V J ANDREWS	W H Manager Grade III	“ “	“ “
	P RAMA MURH THY	Senior Asst		
JADCHERLA	MD SULTAN	Asst.Warehouse Manager	AP State Warehousing Corpn., JADCHERLA, Badepalli Station, MAHABOBNAGAR DIST. 509 301.	08542 233314 “ “ “
	M S NARAYANA	G C P	“	
	G YADAIAH	G C P	“	
	M SUDHAKAR REDDY	Construction Engineer	“	
JADCHERLA (IG)	B RAGHUPATHI REDDY	W H Manager Grade III	AP State Warehousing Corpn., JADCHERLA, Booredypalli Village,Kurnool Road, MAHABOBNAGAR DIST. 509 301.	08542 235618 “ “
	V NARAYANA REDDY	Asst Manager(Tech)Gr-II	“	
	P KRISHNA KUMAR	Asst.Warehouse Manager	“	
JAGAYYAPETA(IG)	E RAMA RAO	Asst Manager(Tech)Gr-II	A.P.State Warehousing Corpn., JAGGAYAPETA-521 175. Krishna District.	08654 226666
	PRASADA RAO N	Asst.Warehouse Manager	“	“
	K RAM BABU	Junior Assistant	“	“
JAGGAYYAPET	D R KRISHNA RAO	G C P	AP State Warehousing Corpn., JAGGAIHPET, Krishna District 521 175.	08654 22197
	G KOTESWARA RAO	G C P		
JAGTIAL	D GOPALAKRISHNA RAJU	W.H Manager Grade I	AP State Warehousing Corpn., JAGITYAL, Karimnagar District 505 327.	08724 221292 “ “ “
	MOHD ASGARUDDIN	W H Manager Grade III	“	
	T MALLAIAH	Junior Assistant	“	
	A HAMEED	G C P	“	
	Md.ISMAIL	G C P		
JAMMIKUNTA	V ANTHAIAH	W H Manager Grade III	AP State Warehousing Corpn., JAMMIKUNTA Karimnagar District 505 122.	08727 253472
	G.NARAYANA	Asst.Warehouse Manager	“	“
	B.BICHA	G C P	“	“
	M NARASIMHA REDDY	Construction Engineer	“	“
JANAGAM (IG)	K SATYANARAYANA	W H Manager Grade III	AP State Warehousing Corpn., JANAGAM, Yaswantapuri Village, Opp. CJITS, Warangal Dist.	9849284006 “ “
	K CHANDRA MOHAN REDDY	W H Manager Grade III		

WH_NAME	EMP_NAME	DESIG_NAME	ADDRESS	PHONE
	V KISHAN	Asst Manager(Tech)Gr-II	506 167 “ “	“
	P RAJIAH	Junior Assistant	“	“
KADAPA	R ESWARA REDDY	W H Manager Grade II	AP State Warehousing Corpn., KADAPA, D.C. Road, KADAPA DIST. 516 001.	08562 241461 “ “
	ABDUL SHUKUR	Asst.Warehouse Manager	“	“
	U VENKATA SWAMY	G C P	“	
	S ALLABAKSH	G C P	“	
KADAPA(IG)	D NARASIMHA REDDY	W.H Manager Grade I	AP State Warehousing Corpn., KADAPA Buga Agraharam Road KADAPA DIST. 516 001.	08562 258999 “ “ “
	S SAI BABA	Asst.Warehouse Manager	“	“
	M TIRUPATHI RAJU	Asst.Warehouse Manager	“	“
	T RAGHURAMAIAH	Junior Assistant	“	“
	K.RAMAKARUNA	Attender	“	“
KAKINADA/CHOLLANG I (IG)	K NAGA KUMAR	W H Manager Grade II	AP State Warehousing Corpn., CHOLANGI Vishwa Godowns, Yanam Road, CHOLLANGI, Kakinada. E.G.DIST. 533 461.	0884 2334053 “ “
	K RAMAKRISHNA REDDY	Asst.Warehouse Manager	“	“
	V.S.V.N.RADHAKRISHN A	Asst Manager(Tech) Gr-III	“	“
KAKINADA-I	CH SURYANARAYANA	G C P	AP State Warehousing Corpn., KAKINADA Port Area, Kakinada	0884 2364357
	K RAMA RAO	G C P	“	“
KAMAREDDY	K RAGHURAMI REDDY	W H Manager Grade III	AP State Warehousing Corpn., KAMAREDDY Industrial Development Area, Kamareddy, NIZAMABAD 503111	08468 220625
	MD WAHEDALI	G C P		
	T RAJU	G C P		
	M A HALEEM	G C P		
KANDUKUR	V C KONDAIAH	G C P	AP State Warehousing Corpn., KANDUKURU Mahadevapuram Road, Kandukuru PRAKASAM DIST. 523 125.	.
KARIMNAGAR	K KRISHNA REDDY	W H Manager Grade II	AP State Warehousing Corpn., KARIMNAGAR, P.B.No.34, KARIMNAGAR DIST. 505 001.	08782 278947
	P R PRABHAKAR RAO	Asst.Warehouse Manager		
	D SAMUEL	G C P		
	MD VAZIR	G C P		
	P.RAJENDER	G C P		
	J BHOOMESWAR	Construction Engineer		
KAVALI	A SREENIVASULU REDDY	W.H Manager Grade I	AP State Warehousing Corpn., KAVALI H.No. 11-33-949, Vengalraonagar, KAVALI NELLORE DIST. 524 201.	08626 243823

WH_NAME	EMP_NAME	DESIG_NAME	ADDRESS	PHONE
	P VIJAYA REDDY	Asst Manager(Tech) Gr-III	“	“
	K RAMAKRISHNUDU	Junior Assistant	“	“
	R CHITTI BABU	G C P	“	“
KHAMMAM(IG)	SB AHMED	W H Manager Grade III	A.P.State Warehousing Corpn., KHAMMAM Khammam District.	08742 285495
KHAMMAM(OWN SG)	B SUNDAR LAL	W H Manager Grade III	“	“
KHAMMAM-I	A RAMA RAO	W H Manager Grade II	AP State Warehousing Corpn., Grain Market Yard, KHAMMAM, KHAMMAM DIST. 507 003.	08742 256709 “
	K SRI HARI	Asst.Warehouse Manager	“	“
KHAMMAM-II	K MANI	Asst.Warehouse Manager	A.P.State Warehousing Corpn., Peddatanda, KHAMMAM-507 003 Khammam District.	08742 243794 “
	K NAGA RAJU	G C P	“	“
KODAD	SK DASTAGIRI	G C P	A.P.State Warehousing Corpn., KODAD(Balaji Nagar) Nalgonda District.	08689 240793 “
	P VISWA SHANTY	Construction Engineer	“	“
KODAD-I(IG)	R PRABHAKAR RAO	W.H Manager Grade I	A.P.State Warehousing Corpn., Shanthinagar, KODAD-I Nalgonda District.	08683 254137
	M C SAIDULU	G C P	“	“
KODAD-II (IG)	M RAJENDRA REDDY	W H Manager Grade III	AP State Warehousing Corpn., KODAD - II Dwarakunta, NALGONDA DIST.508 201.	08683 256156 “ “
	A SAIDULU	Asst.Warehouse Manager	“	“
	A VEERA RAGHAVIAH	G C P	“	“
KORUTLA	K.GANGAIAH	G C P	AP State Warehousing Corpn., KORUTLA, Karimnagar Dist – 505 326	“
KOTABOMMALI (IG)	D L NARAYANA	W.H Manager Grade I	AP State Warehousing Corpn., KOTABOMMALI, Post Nimmada, Via Priya Agraharam, KOTABOMALI (m) SRIKAKULAM DIST. 532 430.	08942 273763
KOTHAGUDEM	S.Kesava Rao	Asst.Warehouse Manager	AP State Warehousing Corpn., KOTHAGUDEM Laxmidevi Palli, Kothagudem, KHAMMAM DISTRICT 507 106	08744 242336 “ “
	A JAYA RAJU	Attender	“	“
	K.Laxmi	G C P	“	“
KURNOOL(IG)	M BALASWAMY	W H Manager Grade III	AP State Warehousing Corpn., KURNOOL(PNL Godowns) Opp: Radio Station L.Venkaiah Nagar Kurnool Dist 518 003	08518 258789 “
	C ANJANEYULU	Junior Assistant	“	“
KURNOOL-I	B E SUDHAKAR	W.H Manager Grade I	AP State Warehousing Corpn.,	08518 257319

WH_NAME	EMP_NAME	DESIG_NAME	ADDRESS	PHONE
	G. MAHABOOB BASHA	G C P	KURNOOL, KURNOOL	“
	B.VENKATESWARLU	G C P	DISTRICT 518 00 3.	“
	SAIKH SALAM MIAH	G C P	“	“
MACHILIPATNAM(IG)	D VENKAIAH	W H Manager Grade II	AP State Warehousing Corpn., MACHILIPATNAM CHILAKALAPUDI (Post) Pedakargraharam Krishna Dist - 521 002	08672 228604
	M SREERAMA MURTHY	Asst.Warehouse Manager	“	“
MADHIRA (IG)	G.LAXMAN RAJU	W.H Manager Grade I	AP State Warehousing Corpn., MADHIRA Denduluru Road Khammam Dist .	9848122422
	P.VINOD KUMAR	Junior Assistant	“	“
MAHABOOBABAD (IG)	T RAMULU	W H Manager Grade III	AP State Warehousing Corpn., MAHABOOBABAD Anantaram (V)&(P) Bayyaram Road, Mahaboobabad Mandal, WARANGAL DIST. 506 001.	08719 243615
	A.SATEESH	G C P	“	“
MANCHIRYAL (IG)	G NARAYANA	W H Manager Grade II	AP State Warehousing Corpn., MANCHEERYAL Gopalvada, Garimilla Village, MANCHEERYAL, ADILABAD DIST. 504 208	9849247948
	N SUBBARAYUDU	W H Manager Grade II	“	“
MANDAPETA	A VISWESWAR RAO	W H Manager Grade III	AP State Warehousing Corpn., MANDAPETA, Main Road, Mandapetam, E.G.DISTRICT 533 308.	08855 232170
	S.GNANA RATNAM	Asst.Warehouse Manager		
	CH VENKATA RAO	G C P		
	SHAIK AKBAR BASHA	G C P		
MANDAPETA (IG)	B S MARKANDEYULU	Asst.Warehouse Manager	A.P.State Warehousing Corpn., MANDAPETA East Godavari District.	08855 230559
	C ASHOK KUMAR	Asst Manager(Tech) Gr-III		
MEDAK(IG)	K SANTOSH REDDY	W H Manager Grade II	AP State Warehousing Corpn., MEDAK, Chetpalli Kalam (P) Balanagar (V) MEDAK DIST. 502 117.	9440414700
	H VENKAIAH	G C P		
METPALLI	G BAZAR	Asst.Warehouse Manager	AP State Warehousing Corpn., METPALLI Near Market Yard, METPALLI KARIMNAGAR 505 325.	08725 225321
	N M MANOHAR RAJU	Asst.Warehouse Manager		
	B LAXMINARAYANA	G C P		
MIRIYALGUDA (IG)	B BHASKAR REDDY	W.H Manager Grade I	A.P.State Warehousing Corpn.,	958689

WH_NAME	EMP_NAME	DESIG_NAME	ADDRESS	PHONE
	P VEERAMALLU	Asst.Warehouse Manager	MIRYALGUDA(R.S) Nalgonda District.	231889
	K NARAYANA REDDY	G C P		
MIRYALGUDA	K YADAI AH	W H Manager Grade III	AP State Warehousing Corpn., MIRYALAGUDA Near Market Yard, Shabunagar, MIRYALAGAGUDA, NALGONDA DISTRICT 508 207	08689 242798
MUSHEERABAD	M NAGESWARA RAO	Junior Assistant	Warehouse Manager AP State Warehousing Corpn., MUSHEERABAD Secunderabad.	040 27532274
NADIKUDI	A SOMASUNDARAM	G C P	AP State Warehousing Corpn.,	08649 257638
	Y.SAMUEL	G C P	NADIKUDI, Guntur District 522 414.	
NADIKUDI (IG)	P JAGADESH RAO	W H Manager Grade II	A.P.State Warehousing Corpn., NADIKUDI-522 414. Guntur District.	08649 246396
NALGONDA	MOHD SHARFUDDIN	W H Manager Grade III	A.P.State Warehousing Corpn., NALGONDA Nalgonda District.	08682 245393
	Y BAZAR	W H Manager Grade III		
NALGONDA(IG)	T GOPAL SINGH	Asst.Warehouse Manager	A.P.State Warehousing Corpn., A.Duppalapalli Mandal, NALGONDA-508 247. Nalgonda District.	08682 248267
	D JWANESH	G C P		
NARASARAOPET-I	S VENKANNA	W H Manager Grade II	AP State Warehousing Corpn., NARSARAOPETA Opp.RTC Bus Stop, Narsaraopeta, GUNTUR DIST. 522 602.	08647 231740
	SK. KHUDDUS	Asst.Warehouse Manager		
	K VEERA REDDY	Asst.Warehouse Manager		
	A VENKANNA	Attender		
	G VEERAI AH	Attender		
	SK SHOWKAT ALI	G C P		
NARASARAOPET-I	ABDUL SATTAR	G C P	AP State Warehousing Corpn., NARSARAOPETA Opp.RTC Bus Stop, Narsaraopeta, GUNTUR DIST. 522 602.	08647 231740
NARSAPUR (IG)	P RAMACHANDRA REDDY	Asst.Warehouse Manager	AP State Warehousing Corpn., NARSAPUR C/O. Sai Pavan Storages, Peechpalem To Pitani Meraka Road, Laxmaneswaram, NARSAPUR, W.G.DIST. 534 2 75.	08814 275623
NELLORE	P MUNIRATNAM NAIDU	W H Manager Grade III	AP State Warehousing Corpn., Nellore, NELLORE DIST 524 005.	08622 271072
	K VENU	G C P		
	B PENCHALAI AH	G C P		

WH_NAME	EMP_NAME	DESIG_NAME	ADDRESS	PHONE
NIDADAVOLU (IG)	V V V SATYANARAYANA	W.H Manager Grade I	AP State Warehousing Corpn., NIDADAVOLU C/o. SAI GODAVARI FARMERS SYNDICATE Godowns, Katakuteswaram, W.G.DISRICT 534 301.	08813 277790
	M KRISHNA RAO	Asst Manager(Tech)Gr-II		
	S BHUSHANAM	Asst.Warehouse Manager		
NIDAMANUR	Y V LAKSHMAIAH	W H Manager Grade II	A.P.State Warehousing Corpn., Uppaluru NIDAMANOOR- 521 102.	0866 5515288
	G V SUBRAHMANYAM	Junior Assistant		
	M KRISHNAIAH	Asst.Warehouse Manager		
NIDAMANUR (IG)	Y V LAKSHMAIAH	W H Manager Grade II	AP State Warehousing Corpn., NIDAMANOOR Kesarapalli Branch Post Office, Gannavaram Mandal, KRISHNA Dist. 521102	08676 256231
	G V SUBRAHMANYAM	Junior Assistant		
NIDAMANUR(UPPULUR) (IG)	T S NAGESWARA RAO	W H Manager Grade II	AP State Warehousing Corpn., UPPALURU (Near Railway Station) Krishna Dist – 521 151	0866 2862828
	V D S CHARY	Asst.Warehouse Manager		
	A KRISHNAMACHARY	AWH Manager		
NIZAMABAD (IG)	MUSTHAQ AHMED	W.H Manager Grade I	AP State Warehousing Corpn., NIZAMABAD Sastry Nagar (Post) Opp: Railway Junction Janakampeta, Nizamabad Dist – 503 186	08462 273286
	R DEVENDER SINGH	G C P		
PALAKOLLU	P KONDALA RAO	Asst.Warehouse Manager	A.P.State Warehousing Corpn., Ellavani Garruvu, Opp: Ganesh Rice Mill, PALAKOLE-534 261. West Godavari District.	08814 223062
	M.DAMODAR RAO	G C P		
	DAMODAR RAO	G C P		
	V L N V MALLIKARJUNA RAO	G C P		
PALAKOLLU - 2 (IG)	M V PURNA CHANDRA RAO	W H Manager Grade II	AP State Warehousing Corpn., PALAKOLU- II Adivipalem (V)&(P) Elamanchali (M) W.G.Dist. 534 261.	08814 224537
	M NARASHIMHA REDDY	Asst.Warehouse Manager		
PALASA	S.SUBBARAYUDU	W H Manager Grade III	AP State Warehousing Corpn., PALASA Tarlakota Village, Palasa Mandal & Post, Srikakulam Dist. 532 221.	08945 242238
	P CHIRANJEEVULU	G C P		
	P NARASIMHULU	G C P		
PALASA(IG)	D E JANARDHANA RAO	Junior Assistant	A.P.State Warehousing Corpn., PALASA(IG) Srikakulam District.	08945 240094
PARVATHIPURAM(IG)	T SEETHARAMAIAH	W.H Manager Grade I	AP State Warehousing Corpn., PARVATHIPURAM ADDAPUSEELA (Post)	08964 229333
	P NARASIMHA MURTHY	Asst.Warehouse Manager		

WH_NAME	EMP_NAME	DESIG_NAME	ADDRESS	PHONE
	Ch.KANAKA RAO	G C P	Vizianagaram Dist – 535 502	
	CH BVSR MURTHY	G C P		
PEDDAPALLI	A.MUTHAIAH	G C P	AP State Warehousing Corpn., PEDDAPALLI, Bandampalli Village, Karimnagar District 505174.	08728 222335
PEDDAPALLI -1 (IG)	D RAMA RAO	W H Manager Grade III	A.P.State Warehousing Corpn., Rangapur PEDDAPALLI Karimnagar District.	
PEDDAPALLI -2 (IG)	A NARAYANA REDDY	W H Manager Grade II	AP State Warehousing Corpn., PEDDAPALLI - II Pedabonkuru, Near Government Degree College, PEDDAPALL, KARIMNAGAR DIST. 505 174.	9849247722
PIDUGURALLA	P V MURALI KISHORE	W H Manager Grade III	AP State Warehousing Corpn., PIDUGURALLA Main Road, Piduguralla, Guntur District 522 413.	08649 252256
	A PRASAD	G C P		
	B V SUBRAHMANYAM	G C P		
PILER	D.SANGAIAH	G C P	AP State Warehousing Corpn., PILER Piler X Road, Piler, CHITTOOR DIST. 517214.	08584 244242
PITHAPURAM (IG)	GOVERDHAN	W H Manager Grade III	AP State Warehousing Corpn., PITHAPURAM C/o. Varma Warehousing Enterprises, Via Gollaprolu, Tadipatri Junction, E.G.DIST. 533 445.	0884 2367731
	B.SATYANARAYANA	Junior Assistant		
PRODDATUR	D LAKSHMI SHAILAJA	W H Manager Grade III	AP State Warehousing Corpn., Korrappadu Road, Proddatur, CUDDAPAH DIST. 516361.	08564 253385
	SHEERI BEGAM	Senior Asst		
	M.MADDAIAH	Attender		
	N KANNAIAH	G C P		
	B V RAMANA RAO	Construction Engineer		
RAJAM	K RAM PRAKASH RAO	W H Manager Grade II	AP State Warehousing Corpn., ARDC GODOWNS, RAJAM SRIKAKULAM DIST. 532 127	08941 2526595
	D SATYAM	Asst Manager(Tech)Gr-II		
	N.NARAYUDU	G C P		
	P ADINARAYANA	G C P		
RAJAMUNDRY (IG)	E R CHANCELLOR	W.H Manager Grade I	AP State Warehousing Corpn., RAJAHMUNDRY, C/o. Sai Agro Investor Godowns, Industrial Estate, Rajavolu Village, RAJAHMUNDR E.G.DIST. 533 124.	0883 2416453
	P VIJAYA BHASKAR REDDY	Asst Manager(Tech)Gr-II		
	A RAM BABU	Asst.Warehouse Manager		
	M SURYANARAYANA	Junior Assistant		

WH_NAME	EMP_NAME	DESIG_NAME	ADDRESS	PHONE
RAMACHANDA PURAM (IG)	M CHANDRA REDDY	W H Manager Grade III	A.P.State Warehousing Corpn., Chodavaram,	08857 244222
	Y SUBASH CHANDRA BOSE	Asst Manager(Tech)Gr-II	Ramchandrapuram(M) RAMCHANDRAPURAM(IG). East Godavari District.	
RAVULAPALEM (IG)	CH R KRISHNA PRASAD	W H Manager Grade III	AP State Warehousing Corpn., RAVULAPALEM ETA Kota,	08855 258654
	V.SIMHADRI APPA RAO	G C P	Podagatlapalli Road, Via Ravulapalem, E.G.District 533 238.	
RAZOLE (IG)	Y PATTABIRAMAIAH	W H Manager Grade III	AP State Warehousing Corpn., RAJOLE, Near Grampanchayati Office, Sompalli Village, Rajole E.G.DIST. 533 242. 08862 222103	
RENIGUNTA(IG)	P LOKANADA NAIDU	W H Manager Grade III	AP State Warehousing Corpn., RENIGUNTA (YERPEDU)	08772 2400800
	A RATNAMIAH	Asst.Warehouse Manager	Near Railway station Chittoor Dist – 517 520	
	G.BASAVA SASTRULU	Asst.Warehouse Manager		
REPALLE	P.PRASANNA KUMAR	Asst.Warehouse Manager	AP State Warehousing Corpn., REPALLE Guntur Dist 522 265.	08648 222152
	K.NAGESWARA RAO	G C P		
	V.KANAKADURGA	G C P		
SAMARLAKOTA(IG)	B VISWESWARA RAO	W H Manager Grade II	AP State Warehousing Corpn., SAMARLAKOTA C/o. Jyothula Agri Storages, ADB Road, Samarlakota,	0884 2329768
SAMARLAKOTA(IG)	I U M N PRASAD NAIDU	Asst Manager(Tech)Gr-II	AP State Warehousing Corpn., SAMARLAKOTA C/o. Jyothula Agri Storages, ADB Road, Samarlakota, E.G.DISTRICT. 533238.	0884 2329768
	K SREE RAMULU	Asst.Warehouse Manager		
	R CHUKKA RAO	Asst.Warehouse Manager		
SANATH NAGAR	CH SUKEERTHI KUMAR	W H Manager Grade III	AP State Warehousing Corpn., SANATHNAGAR H.No.7-20/12/A 13, Moosapet, Near Goods Shed, HYDERABAD.	040 23813111
	S SRI RAMULU	Senior Asst		
SANGAREDDY(IG)	M VENKATESWARULU	W H Manager Grade II	AP State Warehousing Corpn., SANGAREDDY, Malkapur (P)&(V) Medak District 502 295.	08455 230444
SARANGAPUR	K CHANDRA SEKARA REDDY	Asst.Warehouse Manager	AP State Warehousing Corpn., SARANGAPUR, Near AP Dairy Development Federation, Opp: Sri Rama Temple, Hanuman Temple Road Nizamabad Dist. 503 186	9849354871
	S BALLMALLU	G C P		
SATTENAPALLI (IG)	B RAMA NARAYANA REDDY	W H Manager Grade II	AP State Warehousing Corpn., SATTENAPALLI, Near Venna Devi GUNTUR DIST. 522 403	08641 234326
SIDDIPET(IG)	B CHANDRA SEKHAR	W H Manager Grade III	AP State Warehousing Corpn., SIDDIPET Ponnala(V&P)	9849425696

WH_NAME	EMP_NAME	DESIG_NAME	ADDRESS	PHONE
			Medak Dist	
SURYAPET	G.V.SUBBA RAO	Asst.Warehouse Manager	A.P.State Warehousing Corpn., SURYAPETA Nalgonda District.	
TADEPALLI	A SUDHAKAR REDDY	W H Manager Grade III	AP State Warehousing Corpn., TADEPALLI, K.C.Works Post Office, Krishna Nagar (V) Vijayawada to Guntur Road, TADEPALLI, GUNTUR DISTRICT 522 502	08645 272238
	V SURENDRA	Asst Engineer		
	D.RANGANAYAKULU	G C P		
	J RAMULU	G C P		
	K SAMBASIVA RAO	G C P		
TADEPALLI	K PRABHAKAR RAO	G C P	AP State Warehousing Corpn., TADEPALLI, K.C.Works Post Office, Krishna Nagar (V) Vijayawada to Guntur Road, TADEPALLI, GUNTUR DISTRICT 522 502	08645 272238
	DAVID WILSON	Works Maistry		
TADEPALLI	P BALAJEE	Construction Engineer	AP State Warehousing Corpn., TADEPALLI, K.C.Works Post Office, Krishna Nagar (V) Vijayawada to Guntur Road, TADEPALLI, GUNTUR DISTRICT 522 502	08645 272238
TADEPALLI GUDEM(IG)	K S ACHARYULU	W.H Manager Grade I	AP State Warehousing Corpn., TADEPALLIGUDEM Nawabpalem (Post) W.G.Dist 534 146	08818 280067
	B RAMESH	Asst Manager(Tech)Gr-II		
	M SIVANNARAYANA	Asst.Warehouse Manager		
	P SRINIVASU	Junior Assistant		
	P BALASOWRI	G C P		
TADIPATRI	G NAGA RAJU	G C P	AP State Warehousing Corpn., TADIPATRI, Anantapur District 515 411.	08558 22310 (p.p)
TANUKU	KATTA SATYANARAYANA	W H Manager Grade II	AP State Warehousing Corpn., TANUKU ARDC Godowns, Tanuku,	08819 222180
	LVV BHASKAR RAO	Asst.Warehouse Manager		
	SHAIK SHAKEER BASHA	G C P		
	A V S RAJAGOPAL	G C P		
TANUKU(IG)	N SUBRAHMANYAM	W H Manager Grade II	A.P.State Warehousing Corpn., TANUKU(Tetali) West Godavari District.	08819 228009
	P VISWANATH	Asst Manager(Tech)Gr-II		
TENALI	G CH RAMA RAO	W H Manager Grade II	AP State Warehousing Corpn., TENALI Sultanabad, TENALI GUNTUR DIST.	08644 228066
	S MD OSMAN	Asst Manager(Tech)Gr-II		
	B POLA RAO	Senior Asst		
	R VEERAAIAH	Asst.Warehouse Manager		

WH_NAME	EMP_NAME	DESIG_NAME	ADDRESS	PHONE
	Y SAMABASIVA RAO	Asst.Warehouse Manager		
	T RAMAIAH	Asst.Warehouse Manager		
	B. SATYANARAYANA	G C P		
	P SAMBASIVA RAO	G C P		
	E RAJARATNAM	G C P		
TENALI(OWN SG)	Y ANANDA RAO	G C P	AP State Warehousing Corpn., TENALI Sultanabad, TENALI GUNTUR DIST. 522 202.	"
TUNI (IG)	CH VENKATESWAR	W H Manager Grade III	AP State Warehousing Corpn., TUNI C/o. Balatripurasundari Warehousing, Gowraiah Koneru, Tuni, VISAKHAPATNAM. 531 126.	08854 256085
	T.BHAGYANANDA RAO	G C P		
V.T.PALEM(IG)	K RAMA KOTAIAH	W H Manager Grade III	A.P.State Warehousing Corpn., VENKATADRIPALEM Nalgonda District.	08689 240793
	T JAYA PRAKASH REDDY	Asst Manager(Tech) Gr-III		
	B.Veera Reddy	Asst Manager(Tech) Gr-III		
	MD.JOHN PASHA	Junior Steno		
	K.SOMAIAH	G C P		
VEDAYAPALEM	B V RAMANAIAH	W H Manager Grade II	AP State Warehousing Corpn., VEDAYAPALEM, Nellore District 524 004.	0861 2327457
	B DAMODARAM	Junior Assistant		
	P SOBJAN	G C P		
VEMULAPALLI(IG)	K NAGABHUSHANAM	W H Manager Grade III	AP State Warehousing Corpn., VEMULAPALLI (via Dwarapudi) E.G.DIST - 533 341	08857 227937
VENKATADRIPALEM	K.PUSHPA	Attender	VENKATADRIPALEM, Miryalaguda, NALGONDA DIST. 508 207.	08689 242823
VISAKHAPATNAM (IG)	T MURALIDHAR	Asst Manager(Tech) GR.I	AP State Warehousing Corpn., VISHAKAPATNAM Vepakunta (Post) Near Lakshmipuram Railway gate VISHAKAPATNAM Dist – 530047	0891 2760760
VIZIANAGARAM	G VENKATESWAR RAO	W H Manager Grade II	AP State Warehousing Corpn., VIZIANAGARAM, Kotha Agraharam, VIZIANAGARAM 531 201.	0892 2223902
	P D MALLIK	Asst Manager(Tech)Gr-II		
	GVS BHANU MURTHY	Asst.Warehouse Manager		
	M BABU RAO	G C P		
	V.SATYANARAYANA	G C P		

WH_NAME	EMP_NAME	DESIG_NAME	ADDRESS	PHONE
VIZIANAGARAM (IG)	K CH MANDULAI AH	Superintendent		
WANGAPALLI(IG)	S IBRAHIM BASHA	W.H Manager Grade I	AP State Warehousing Corpn., WANGAPALLI Near Ramojipeta Village, Yadagirigutta Mandal NALGONDA DIST. 508 286	08685 237561
	P SREENIVAS	Asst Manager(Tech) Gr-III		
	M RAGHU MOHAN REDDY	Asst Manager(Tech) Gr-III		
	D KRISHNA	G C P		
WARANGAL	V KAMALAKAR	W H Manager Grade III		
	B THIRUMALAI AH	G C P		
WARANGAL(IG)	B SATYANANDAM	W.H Manager Grade I	A.P.State Warehousing Corpn., Darmaram WARANGAL Warangal District.	9440282515
WYRA(IG)	Y L V PRASAD	W H Manager Grade II	AP State Warehousing Corpn., WYRA TATIPUDI (v)&(p) Wyra Mandal, KHAMMAM DIST. 507 165.	08749 252715
	G NAGABUSHANAM	Junior Assistant		
	R VENKATESWARLU	G C P		

Chapter 11
Monthly Remuneration received by Officers and Employees, including the System of
Compensation as provided in Regulations
[Section 4(1)(b)(x)]

S No	Designation	Monthly Remuneration including its composition System of compensation to determine Remuneration as given in regulation	
Remuneration includes (Pay + HRA + DA + CCA)			
1	Managing Director	53161.00	
2	Secretary	30499.00	
3	Executive Engineer	29859.00	
4	General Manager	30499.00	
5	Construction Engineer	22457.00	
6	Regional Manager	24275.00	
7	Deputy Manager	19064.00	
8	W.H Manager Grade I	19869.00	
9	W H Manager Grade II	15812.00	
10	W H Manager Grade III	12901.00	
11	Superintendent	14846.00	
12	Accountant	14144.00	
13	Asst Engineer	16732.00	
14	Asst Manager(Tech) GR-I	14466.00	
15	Asst Manager(Tech)Gr-II	12577.00	
16	Asst Manager(Tech) Gr-III	9813.00	
17	Senior Steno Cum PA to MD	13291.00	
18	Senior Asst	11503.00	
19	Asst.Warehouse Manager	10664.00	
20	Junior Assistant	8214.00	
21	Junior Steno	8668.00	
22	Typist	8044.00	
23	Driver	9623.00	
24	Attender	8992.00	
25	Fitter	10890.00	
26	Peon	8875.00	
27	G C P	7987.00	
28	Wire Men	9559.00	
29	Works Maistry	8182.00	

Chapter 12
Budget Allocated to Each Agency including Plans etc.
[Section 4(1)(b)xi]

Agency	Plan/Programme/ Scheme/Project/ Activity/Purpose for which budget is allocated	Proposed expenditure	Expected Outcomes	Report on disbursements made or where such details are available (web site, reports, notice board etc.)
-NIL-				

Chapter 13
Manner of Execution of Subsidy Programmes
[Section 4(1)(b)xii]

Name of programme/ activity	Nature/scale of subsidy	Eligibility criteria for grant of subsidy	Designation of officer to grant subsidy
Not applicable to Corporation, as there is no subsidy from Government			

Chapter 14
Particulars of Recipients of Concessions, Permits or Authorization Granted by the
Public Authority
[Section 4(1)(b)xiii]

Institutional and Individual Beneficiaries

Name of programme/scheme:				
Sl. No	Name & address of recipient institutions/ Individuals	Nature/ quantum of benefit granted	Date of grant	Name & Designation of granting authority
1	2	3	4	5
1	Farmers	The Corporation is allowing 35% rebate in storage charges to the farmers on their agricultural products. The same rebate is also being given to the self-help groups and primary agricultural cooperative societies also in addition the rebates in storage charges are also being allowed to the cooperative sectors like A.P.Markfed, NAFED, and its apex bodies to the extent of 20%. A general rebate of 10% in storage charges is being allowed to all the depositors in all the State Warehousing Corporation owned godowns to encourage and develop the custom position in the Corporation owned godowns.	This Office Circular Dt.22.02.2006 & 06.04.2006	Managing Director
2	Traders			
3	Cooperative			
4	AP. Markfed			
5	NAFED, and Its Apex bodies			

Chapter 15
Information Available in Electronic Form
[Section 4(1)(b)x(iv)]

Electronic format	Description (site address/location where available etc.)	Contents or title	Designation and address of the custodian of Information (held by whom?)
Website	www.apswhc.com/address/RTI.htm	1) Payroll and its related activities such as Provident Fund A/c, Employees Income Tax., etc. 2) Business Review System Complete Business Review repots, periodical capacity and occupancy reports etc. 3) Income & Expenditure Reports Warehouse Wise Income and Expenditure entry and reports 4) Employee Information. Employee Present working place, working since details, staff position at all the warehouses etc., 5) Outstanding Management System FCI and other depositors claim and realization particulars. 6) Financial Accounting System Focus Accounting Package being used.	Dy.Manager(IT)

Chapter 16
Particulars of Facilities available to Citizens for Obtaining Information
[Section 4(1)(b)xv]

Facility	Description (Location of Facility/Name etc.)	Details of Information made available
1	2	3
Notice Board	Notice Board depicted in the office	Tender notices of construction works and Repairs and maintenance works and Tenders for H&T works .
News Paper Reports	Leading Dailies	
Public Announcements	--	--
Information Counter	--	--
Publications	Pamphlets/Brouchers	Activities of the Corporation
Office Library	--	--
Websites	www.apswhc.com	Official website of APSWC with all particulars
Other Facilities (name)	--	--

Chapter 17
Names, Designations and other Particulars of Public Information Officers
[Section 4(1)(b)xvi]

APIO/PIO/APPELLATE AUTHORITY

S No	Name of office/ administrative unit	Name & designation of PIO	Office Tel: Residence Tel: Fax:	Email
1	Chengicherla Warehouse	Sri J. Shankar Rao Warehouse Manager, Gr.I/ APIO	040-25504773	
2	Head Office	Sri E.Prasad Rao General Manager(P&A)/PIO	040-24603195	
3	Head Office	Sri Md.Shafiquzzaman, I.A.S, Managing Director First Appellate Authority	040-24607970	

Chapter 18
Other Useful Information
[Section 4(1)(b)xvii]

-- NIL --